

Standard Equipment/Optional Equipment

Standard Equipment

Backlit multifunction display	AC drive motor
Truck activated by entering unique PIN code or by ignition key	Automatic braking on releasing butterfly switch
Safe operator compartment with cushioned full-suspension platform	Electromagnetic emergency brake acting proportionally to the load weight
Workstation incorporating storage compartments	Active castor wheels (on the five-point contact HP version)
Clipboard	Cushion drive wheel
Adjustable backrest	Single or tandem polyurethane load wheels
Power-assisted steering, adjustable steering resistance	Electric horn
Self-centering steering	Low temperature protection to -10°C
Automatic speed reduction on turns	

Optional Equipment

Other fork dimensions (length to 2900 mm)	Equipments on the pole
Drive wheel: polyurethane, cushion non-marking or wet grip	Support for data terminal or barcode reader (centre)
Single or tandem greasable load wheels	Data terminal on the bow (front)
Inching button on each side (forward direction)	Battery on rollers for side change
Adjustable Linde control handlebars	Cold store version to -35°C
Load backrests	

Other options available on request.



Low-Level Order Picker Capacity 2000 - 2400 kg N 20, N 20 HP, N 24 HP

Series 132

Safety

Unique Linde twin-grip steering and chassis design ensure that no part of operator's body is exposed outside its contours at any time. Steel front shield and twin-grip hand guard provide additional protection. The front driving position affords optimum visibility for enhanced safety and efficiency.

Performance

The Linde drive system employing advanced control technology translates the powerful output of the maintenance-free AC traction and pump motors into seamless productivity. The 3 kW drive motor delivers full power to give 13% gradeability and safe starting on gradients without rollback. A wide range of batteries is available to match individual order picking applications.

Comfort

A perfect interface between operator and truck is assured with the new Linde N series design concept. The series incorporates the unique Linde twin-grip steering and control system for effortless travelling and manoeuvring. Truck functions are actuated by tactile, thumb operated dual controls intuitively grouped on the protected steering control head for ease of use by either hand. A low, cushioned platform and profiled scoop seat further enhance operator comfort.

Reliability

The new N series is constructed for consistent reliability in demanding applications. Its compact, robot-welded chassis ensures maximum structural integrity and durability. The rugged structure and components provide a low centre of gravity for excellent stability.

Service

Efficiency at work, efficiency in servicing. With uptime ratios of up to 1000 hours between services and a computerised diagnostic system, maintenance intervals are minimal and operating costs are reduced. Easy accessibility of all components and the maintenance free AC technology employed play an additional part in maximising uptime.

Features

Drive system

- Four-point contact configuration for maximum stability (N 20)
- Maximum speed 10 km/h laden, 12 km/h unladen
- Automatic regenerative braking as traction butterfly is released to neutral or opposite direction of travel is selected
- Electromagnetic braking initiated by the emergency stop button acts on the drive motor, proportional to the load carried



High-performance option (HP)

- Five-point contact configuration for optimum stability (N 20 HP/N 24 HP)
- Electronically controlled, hydraulically suspended active castor wheels automatically select optimum ratio between stability and traction for constant ground contact
- Maximum speed 12 km/h laden and unladen

Comprehensive energy solutions

- Vertical battery change as standard, optional side battery change left or right
- Wide range of batteries (low & high) from 270 Ah (3 PzS) to 620 Ah (4 PzS)
- Battery locking system for side change option secures battery in compartment and assists the battery change

Linde twin-grip steering controller

- Superbly functional twin-grip steering controller
- All controls ergonomically grouped on twin grip controller for convenient use by either hand
- Optimum protection for both hands
- Twin-grip design minimises operator's arm movements when turning

CAN bus connectivity

- Integrated CAN bus diagnostic system for faster analysis and shorter service intervals
- Performance parameters can be configured by the service technician to suit individual applications



Workstation

- Wide, easy access from either side
- Ergonomic and intuitive control layout
- Generous storage compartments for shrink wrapping, pens, gloves, etc.
- Digital instrument display
- Padded, adjustable scoop seat provides additional comfort
- A cushioned platform isolates operator from surface vibrations
- Excellent all-round visibility



AC motor

- Powerful, high-torque 3 kW AC drive motor
- Moisture and dust-proof maintenance-free motor
- 13% gradeability performance fully laden
- Safe starting on gradients without rollback
- Responsive acceleration to maximum speed within 5 metres



Power steering

- Effortless, proportional electric power steering with positive feedback
- Self centring steering for faster picking cycles
- Automatic speed reduction when cornering

查詢請聯絡我們:



我們是林德在香港的銷售伙伴
iTL 領捷科技(香港)有限公司
Insights Technology (H.K.) Ltd.
☎ +852 2907 9266
🌐 www.ithkl.com

Linde Material Handling GmbH, Postfach 10 01 36, 63701 Aschaffenburg, Germany
Phone +49.6021.99-0, Fax +49.6021.99-1570, www.linde-mh.com, info@linde-mh.com



Subject to modification in the interest of progress. Illustrations and technical details could include options and not binding for actual constructions. All dimensions subject to usual tolerances.

Printed in Germany 056.e..2.0713.indd.KI

Technical Data according to VDI 2198

Characteristics		LINDE		LINDE		LINDE	
1.1	Manufacturer	LINDE		LINDE		LINDE	
1.2	Model designation	N20		N20HP		N24HP	
1.2a	Series	132		132		132	
1.3	Power unit	Battery		Battery		Battery	
1.4	Operation	Order Picker		Order Picker		Order Picker	
1.5	Load capacity	Q (t)	2.0 ¹⁾	2.0 ¹⁾	2.4 ¹⁾	2.4 ¹⁾	2.4 ¹⁾
1.6	Load centre	c (mm)	1200	1200	600	600	600
1.8	Axle centre to fork face	x (mm)	1763 / 1702 ²⁾	1763 / 1702 ²⁾	963 / 902 ²⁾	963 / 902 ²⁾	963 / 902 ²⁾
1.9	Wheelbase	y (mm)	2325 / 2264 ³⁾²⁾	2325 / 2264 ³⁾²⁾	1525 / 1464 ³⁾²⁾	1525 / 1464 ³⁾²⁾	1525 / 1464 ³⁾²⁾
2.1	Service weight	(kg)	1160	1160	1115	1115	1115
Wheels/Tyres							
3.1	Tyres rubber, SE, pneumatic, polyurethane	V+P/P ⁴⁾⁵⁾		V+P/P ⁴⁾⁵⁾		V+P/P ⁴⁾⁵⁾	
3.2	Tyre size, front	Ø 254 x 102		Ø 254 x 102		Ø 254 x 102	
3.3	Tyre size, rear	Ø 85 x 105		Ø 85 x 105		Ø 85 x 105	
3.4	Auxiliary wheels (dimensions)	Ø 125 x 60		Ø 125 x 60		Ø 125 x 60	
3.5	Wheels, number front/rear (x = driven)	1x + 1 / 2 (1 / 4) ⁶⁾		1x + 2 / 2 (1x + 2 / 4) ⁶⁾		1x + 2 / 2 (1x + 2 / 4) ⁶⁾	
3.6	Track width, front	b10 (mm)	544	544	544	544	544
Dimensions							
4.4	Lift	h3 (mm)	120	120	120	120	120
4.8	Height of seat/stand on platform	h7 (mm)	900 / 1000	900 / 1000	900 / 1000	900 / 1000	900 / 1000
4.9	Height of tiller arm in operating position, min/max	h14 (mm)	1140 / 1190	1140 / 1190	1140 / 1190	1140 / 1190	1140 / 1190
4.15	Height, lowered	h13 (mm)	85	85	85	85	85
4.19	Overall length	l1 (mm)	3747 ³⁾	3747 ³⁾	2547 ³⁾	2547 ³⁾	2547 ³⁾
4.20	Length to fork face	l2 (mm)	1397 ³⁾	1397 ³⁾	1397 ³⁾	1397 ³⁾	1397 ³⁾
4.21	Overall width	b1/b2 (mm)	790	790	790	790	790
4.22	Fork dimensions	s/e/l (mm)	60 x 166 x 2350	60 x 166 x 2350	60 x 166 x 1150	60 x 166 x 1150	60 x 166 x 1150
4.25	Fork spread, min/max	b5 (mm)	520	520	520	520	520
4.34e	Aisle width with load length 2400 mm	Ast (mm)	4110	4110	-	-	-
4.35	Turning radius	Wa (mm)	3158 / 3090 ³⁾²⁾	3158 / 3090 ³⁾²⁾	2358 / 2290 ³⁾²⁾	2358 / 2290 ³⁾²⁾	2358 / 2290 ³⁾²⁾
Performance							
5.1	Travel speed, with/without load	(km/h)	10 / 12	12 / 12	12 / 12	12 / 12	12 / 12
5.2	Lifting speed, with/without load	(m/s)	0.031 / 0.039	0.031 / 0.039	0.031 / 0.039	0.031 / 0.039	0.031 / 0.039
5.3	Lowering speed, with/without load	(m/s)	0.076 / 0.073	0.076 / 0.073	0.076 / 0.073	0.076 / 0.073	0.076 / 0.073
5.8	Maximum climbing ability, with/without load	(%)	6.0 / 17.0	8.0 / 17.0	-	-	-
5.9	Acceleration time, with/without load	(s)	1.4 / 1.0; 1.5 / 1.2 ⁷⁾	1.4 / 1.0; 1.5 / 1.2 ⁷⁾	-	-	-
5.10	Service brake		Electro-magnetic	Electro-magnetic	Electro-magnetic	Electro-magnetic	Electro-magnetic
Drive							
6.1	Drive motor, 60 minute rating	(kW)	3	3	3	3	3
6.2	Lift motor rating at 53 15%	(kW)	1	1	1.2	1.2	1.2
6.3	Battery according to DIN 43531/35/36 A,B,C,no		43 535 / B	43 535 / B	43 535 / B	43 535 / B	43 535 / B
6.4	Battery voltage/rated capacity (Sh)	(V/Ah)	24 / 620	24 / 620	24 / 620	24 / 620	24 / 620
6.5	Battery weight (± 5%)	(kg)	485	485	485	485	485
6.6	Power consumption according to VDI cycle	(kWh/h)	0,48	0,48	0,48	0,48	0,48
8.1	Type of drive control		LAC	LAC	LAC	LAC	LAC

1) With evenly distributed load.
 2) lowered/raised
 3) -100 mm = 3 Pz5; ± 0 mm = 4 Pz5; + 50 mm = 5 Pz5
 4) Drive Wheel Option: rubber non marking, Polyurethane and wet grip

5) Solid rubber + polyurethane / polyurethane
 6) Figures in parenthesis with tandem load wheels.
 7) forward; backward

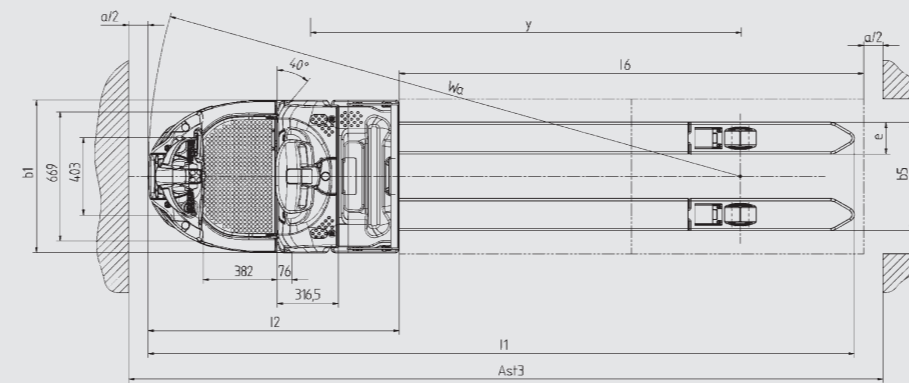
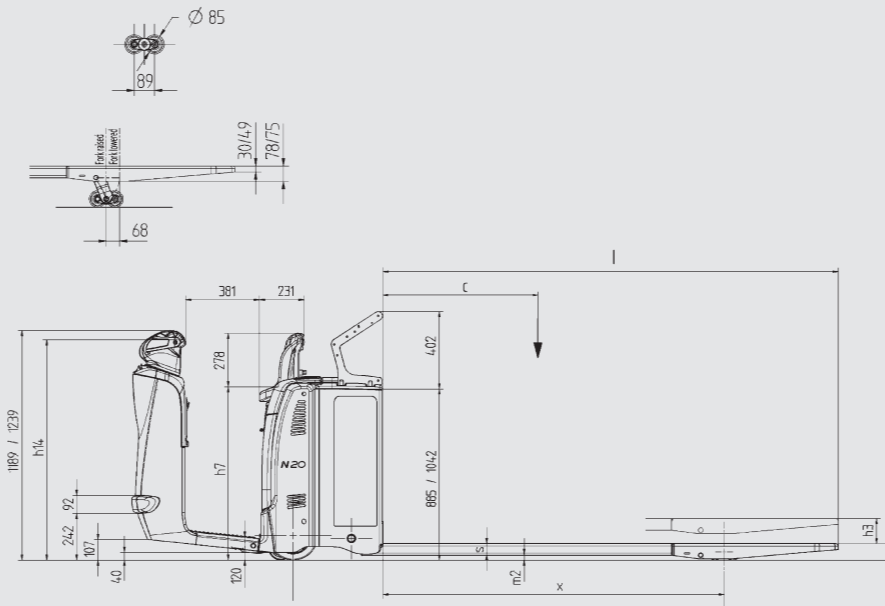

AST = Wa - x + l6 + a
 Security distance a = 200 mm

+/- 5%	N 20				N 24			
	Forward		Backwards		Forward		Backwards	
	unladen	laden	unladen	laden	unladen	laden	unladen	laden
Version 4 points	12 km/h	10 km/h	10 km/h	10 km/h	-	-	-	-
Version 5 points	12 km/h	12 km/h	10 km/h	10 km/h	12 km/h	12 km/h	10 km/h	10 km/h

