

MT15 額定承載能力為 1.5 t，作為經濟型的步行式電動托盤搬運車，是輕工況作業的理想解決方案。
 MT 15 is an economic pedestrian pallet truck, with load capacity of 1500kg, is ideal solution for light application.



相比手動液壓車，全電動托盤搬運車 MT15 旨在幫助操作者釋放勞動強度，提高工作效率。
 Compare with hand pallet truck, MT15 eliminates the physical effort and improves working efficiency

	手動液壓車 Hand Pallet truck	電動托盤搬運叉車 Electric Pallet truck
勞動效率 Efficiency	★★	★★★★★
人力數量 Labor	👤👤👤	👤
勞動強度 Work hard	💧💧	💧
工人接受度 Happiness	😞	😊
綜合使用成本 Cost	\$\$\$	\$

經市場驗證，MT15 的工作效率是手動液壓車的 2 倍，在人工成本越來越貴的今天，MT15 可為您帶來可觀的成本節約。

The efficiency of MT15 is twice better than hand pallet truck, can help you to reduce working cost.

🚛 + 👤 = \$\$\$\$\$\$

🚛 + 👤 = \$\$ 每年節省成本 SAVE COST

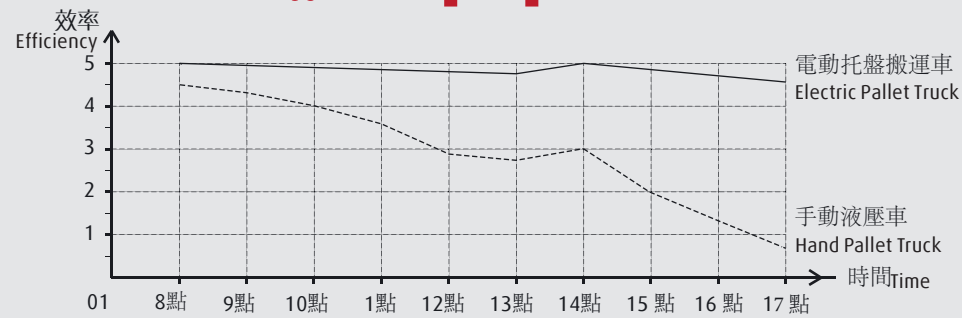

若有技術參數或配置更改，恕不另行通知；所示圖表可能含非標準配置。
 Subject to modification in the interests of progress, illustration and technical details not binding for actual constructions and may show the optional equipments.

1133_MT15_D-01_201412



德國技術-電動托盤搬運叉車 1.5噸
 MT15
 Electric Pallet Truck 1500kg

1133

安全性 Safety

得益於全電動的驅動、提升電機，MT15 讓司機遠離繁重的體力勞動。低位安裝的長舵柄保證叉車與駕駛員之間足夠的安全距離，同時轉向輕便。電池過度放電保護，當剩餘20%電量時叉車將自動切斷提升功能，確保更高的電池壽命。Thanks to its traction and lift motors, MT15 truck eliminates the physical effort which causes physical stress and strain to users. The long tiller mounted on low position ensures enough safety distance between operator and truck as well as keeping steering effort low. Battery discharge indicator with automatic lift cut-off function when 20% rest capacity for higher battery lifetime.

高性能 Performance

標配85Ah免維護大容量電池，續航能力強。貨叉尖端的輔助輪提供良好的通過性。內置充電機操作簡單方便，滿足隨時充電。平衡輪系統保證轉彎時的穩定性，並避免刮擦。85Ah maintenance-free battery lasts longer. Additional entry rollers ensure easy pallet entry. Built-in charger provides more convenient operation, you can charge anywhere and anytime. Castor wheel system provides more stability when cornering and avoid scraping.

舒適性 Comfort

集中式操縱手柄，操縱叉車的行駛、提升。聚氨酯驅動、承載輪的運用保證叉車適應各種路面狀況，噪音低。緊湊的車身設計即使在狹窄的空間內也能實現輕鬆、精確的控制。A joystick controls traction and lift. The use of polyurethane drive and load wheels ensures impressively quiet operation on different application. Its compactness guarantees easy and precise maneuvering even in the tightest spaces.

可靠性 Reliability

MT15 配置進口電機，動力強勁，性能可靠穩定。堅固的金屬蓋板有效保護驅動系統，同時為腳部提供保護。質量和可靠性值得信賴。MT15 is equipped with imported drive motor, provides higher performance and stability. Robust metal cover protects the drive system, also provides safety protection on feet. Achieve an optimal quality and reliability.

易維護 Service

採用進口電機，維護保養間隔比普通叉車延長20%，減少維護成本。摒棄傳統的液壓提升系統，使維護工作大大減少。Imported drive motor extends uptime between maintenance intervals around 20% compare with others, reduces the service cost. The absence of a hydraulic lift system reduces service working.



查詢請聯絡我們:



我們是林德在香港的銷售伙伴
 iTL 領捷科技(香港)有限公司
 Insights Technology (H.K.) Ltd.
 +852 2907 9266
 www.ithkl.com

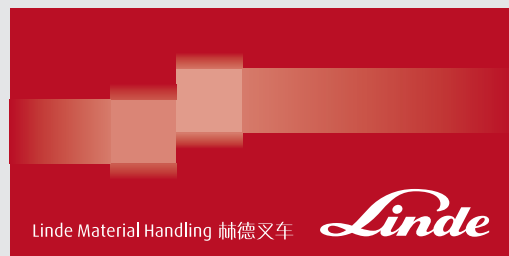

叉車技術參數 Technical Data

特性 Characteristics	1.1	製造廠商	Manufacturer	Linde
	1.2	型號	Model designation	MT15
	1.3	動力	Power unit	蓄電池 Battery
	1.4	操作方式	Operation	步行式 Pedestrian
	1.5	額定承載能力	Load capacity	Q(kg) 1500
	1.6	載荷中心距	Load centre	c(mm) 600
	1.8	前懸距	Axle centre to fork face	x(mm) 946
	1.9	軸距	Wheelbase	y(mm) 1293
	重量 Weights	2.1	自重	Service weight
2.2		滿載時的橋負荷, 驅動側 / 承重側	Axle load with load, drive/load side	kg 510/1180
2.3		空載時的橋負荷, 驅動側 / 承重側	Axle load without load drive/load side	kg 160/40
車輪及輪胎 Wheels and Tyres	3.1	輪胎, 驅動側 / 承重側	Tyre,operator/load side	聚氨酯 PU
	3.2	輪胎尺寸, 驅動側	Tyre size, drive side	mm 200x70
	3.3	輪胎尺寸, 承重側	Tyre size, load side	mm 80x70
	3.4	附屬輪尺寸	Auxiliary wheel, size	mm 80x30
	3.5	車輪數量, 驅動側 / 承重側 (x= 驅動輪)	Wheels number, drive/load side(x=driven)	1X+2/4
	3.6	輪距, 驅動側	Track width, drive side	mm 410
	3.7	輪距, 承重側	Track width, load side	mm 380
尺寸 Dimensions	4.4	提升高度	Lift	h3(mm) 115
	4.9	作業時手柄高度	Height of tiller arm in operation position, min./max.	h14(mm) 800/1170
	4.15	下降後貨叉距地高度	Fork height,lowered	h13(mm) 85
	4.19	總體長度	Overall length	l1(mm) 1660
	4.20	車體長度 (不含貨叉)	Length to fork face	l2(mm) 510
	4.21	車體寬度	Overall width	b1(mm) 574
	4.22	貨叉尺寸	Fork dimensions	s/e/l(mm) 48x160x1150
	*4.25	過貨叉距離 (最小 / 最大)	Fork spread, min./max.	b5(mm) 540
	4.32	軸距中心離地間隙	Ground clearance, center of wheelbase	m2(mm) 37
	4.34	直角堆垛通道寬度, 800x1200 沿貨叉	Aisle width,800x1200mm pallet lengthwise	Ast(mm) 1880
4.35	轉彎半徑 (貨叉提升)	Turning radius(fork raised)	Wa(mm) 1540	
性能 Performances	5.1	行駛速度, 滿 / 空載	Travel speed, with/without load	km/h 4.2/4.6
	5.2	提升速度, 滿 / 空載	Lift speed,with/without load	m/s 0.03/0.053
	5.3	下降速度, 滿 / 空載	Lower speed, with/without load	m/s 0.049/0.036
	5.8	最大爬坡能力, 滿 / 空載	Maximum climbing ability, with/without load	% 4/10
	5.9	加速時間, 滿 / 空載	Acceleration time, with/without load	s 10.7/9.5
驅動 Drive	6.1	驅動電機功率 (60 分鐘)	Drive motor output (60 min.rating)	kw 0.45
	6.2	提升電機功率, 15% 功率	Lift motor output(15% rating)	kw 0.8
	6.3	蓄電池, 根據 DIN 標準	Battery according to DIN 43 531/35/36A,B,C,no	no
	6.4	蓄電池電壓 / 額定容量 (5 小時放電量)	Battery voltage/rated capacity(5h)	V/Ah 2x12V/85
	6.5	電池重量 (±5%)	Battery weight(±5%)	kg 52
其他 Others	8.1	驅動控制方式	Type of Drive control	DC speed
	8.4	駕駛員耳邊噪音水平	Sound level at driver's ear	dB(A) 69
標準叉車的參數根據實際裝備會有所變化 Figures for standard version may vary when options equipment is fitted *備有520及685mm Optional for 520 and 685mm				

特點 Features

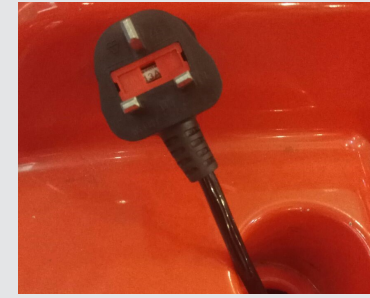

內置充電器操作更靈活, 工況適用性更佳
 Built-in charger makes operation more convenient, the operator can charge anywhere and anytime



電池放電保護, 當剩餘 20% 電量時叉車將自動切斷提升功能, 確保電池壽命
 Battery discharge indicator with automatic lift cut-off function when 20% rest capacity for higher battery lifetime



堅固的金屬蓋板有效保護驅動系統, 同時為腳部提供保護
 Robust metal cover protects the drive system, also provides safety protection on feet



貨叉尖端的輔助輪提供良好的通過性
 Additional entry rollers ensure easy pallet entry

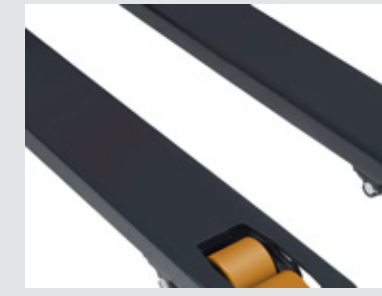

堅固的底盤及加強型的貨叉結構設計
 Robust chassis with reinforced fork-structure

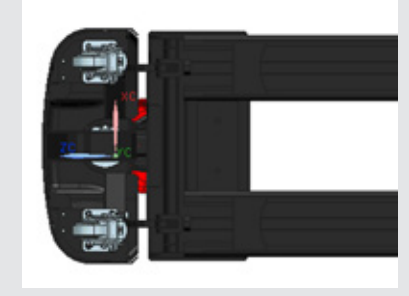

平衡輪系統保證轉彎時的穩定性, 並避免刮擦
 Castor wheel system provides more stability when cornering and avoids scraping

多種容量免維護電池可選:
 2x12V 85Ah
 2x12V 64Ah
 Powerful maintenance-free batteries for multi-application

進口驅動系統, 動力強勁, 維護保養間隔延長 20%, 減少維護成本
 Imported drive motor, provides high performance and stability, extends uptime between maintenance intervals around 20% compare to local one, reduces the service cost

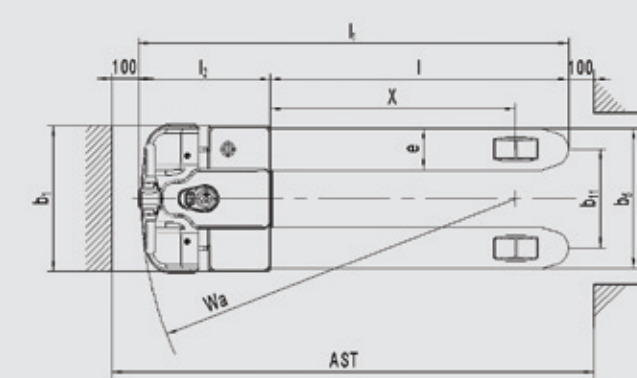
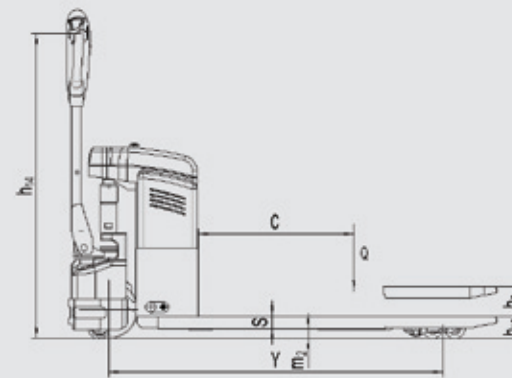

可選配置 Optional Equipment

- 64Ah 免維護電池
- 貨叉寬度: 520mm, 685mm
- 貨叉長度: 800mm, 1000mm, 1220mm
- 橡膠驅動輪
- 聚氨酯單承載輪
- 擋貨架

- 64Ah maintenance-free battery
- Fork width: 520mm, 685mm
- Fork length: 800mm, 1000mm, 1220mm
- Cushion rubber drive wheel
- Single polyurethane load wheel
- Load backrest