



TAWI

ViperHoist

New Advanced
Addition to the
TAWI Hoist Line

We are System Integrator of TAWI in Hong Kong
iTL 領捷科技(香港)有限公司
Insights Technology (Hong Kong) Limited
+852 2907 9266 contact@ithkl.com



Smart lifting

www.TAWI.com

The ViperHoist - High Flexibility

The TAWI ViperHoist is the new most flexible addition to the TAWI hoist line! It is one of the world's fastest hoists making it your best choice for efficient and safe lifting. The ViperHoist offers good ergonomics, easy, safe and flexible handling for all types of applications. Advanced design, low energy consumption and low cost of ownership. The hoist comes in two models: ViperHoist60 with max capacity of 60 kg and ViperHoist120 which can handle weights up to 120 kg. Both models offer quick and smooth operation.

The ViperHoist has a lifting speed of 0.75 m/s for max 60 kg and 0.35 m/s for max 120 kg, which makes it very fast.

The ViperHoist is easy to install and require very little maintenance. It is a reliable equipment that offers great flexibility and easy handling. High quality, great flexibility and low cost cycle cost makes it easy to choose the ViperHoist.

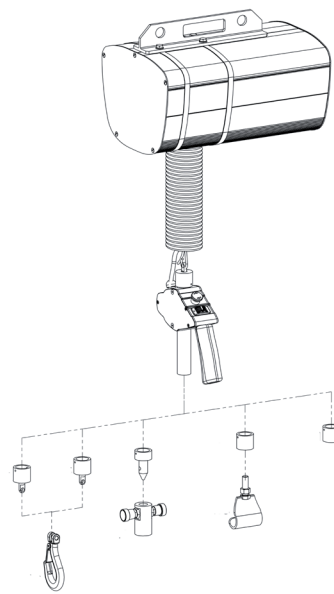

The ViperHoist is designed to offer high flexibility to the customer. Any desired tool can be combined with the Viper. A quick coupling tool enables higher flexibility and use of any tool on the same hoist, such as a hook, special hook, vacuum tools, clamp tools or any customized tools according to the customer's requirements.

The swiveling tool enables rotations of the load. Use the same hoist to lift any type of goods!

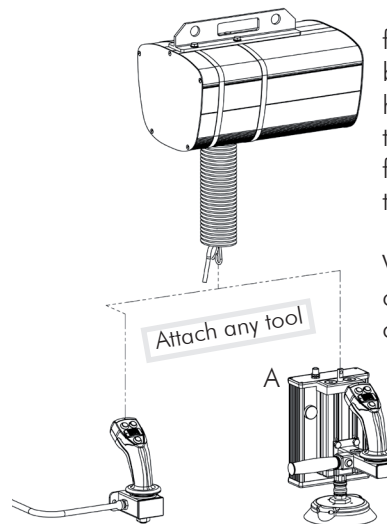

The handle can be separated from the hoist enabling flexibility of the positioning of the handle. Add an angle adapter to lift from various angles, from above, the side, turn and tilt.

Variable speed joystick handle combined with a special vacuum tool (A).

Control Options

Our ergonomically designed handles are available in different designs made to provide comfort, ease and smooth movement while operating. Available options are one handed pistol grip (Standard), Joystick Control Dual & Adjustable joystick control. All to suit your specific needs and requirements.



One handed pistol grip



Joystick control



Dual & Adjustable joystick control

Variable Speed Control

Choose at any point how fast or slow you need to move. Ideal for applications that require high speed at some points and slow, precise movements at other points. The Viper is one of the worlds fastest hoist with a lifting speed of 0.75 m/s for max 60 kg and 0.35 m/s for max 120 kg.

Customized Tooling

The Viper was designed with the customer in mind, with our customizable tooling options operators are able to handle variety of applications. Combined with a fast coupling, several tools can quickly be changed and used on the same hoist.



Fork tool used for lifting large aluminum profiles



Tool for lifting bundles of paper sacks



Battery clamp tool



Roll handling pneumatic gripper, paper roll with adjustable joystick control



Lifting glass car wind- shields using dual joystick control



Special tool for lifting printers

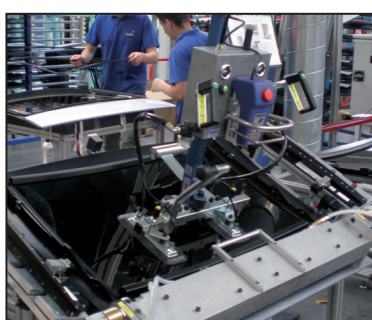

Special tool used to lift car roofs in glass



Two different types of clamping tools used with to lift ceramic toilet seats.



An outbalanced boom for reel lifting.



Special pallet lifter tool



lifting two containers at a time with a mechanical tool. Two adjustable hooks on a yoke.



Hook tool

Safe, Simple, Lightweight

Minimize manual lifting that can put strain on the body and lift easy, safe and ergonomically by using the Viper.

- Light-weight control housing allow for swift movement.
- Reduce operator injury with capacities up to 120 kg.

General Description

1. Suspension
2. Top unit
3. Power supply - 230V 50Hz/60Hz
4. Maneuver cable
5. Lifting wire
6. Wire attachment
7. Emergency stop
8. Operation thumb wheel
9. Handle
10. Tool attachment
11. Attach any tool

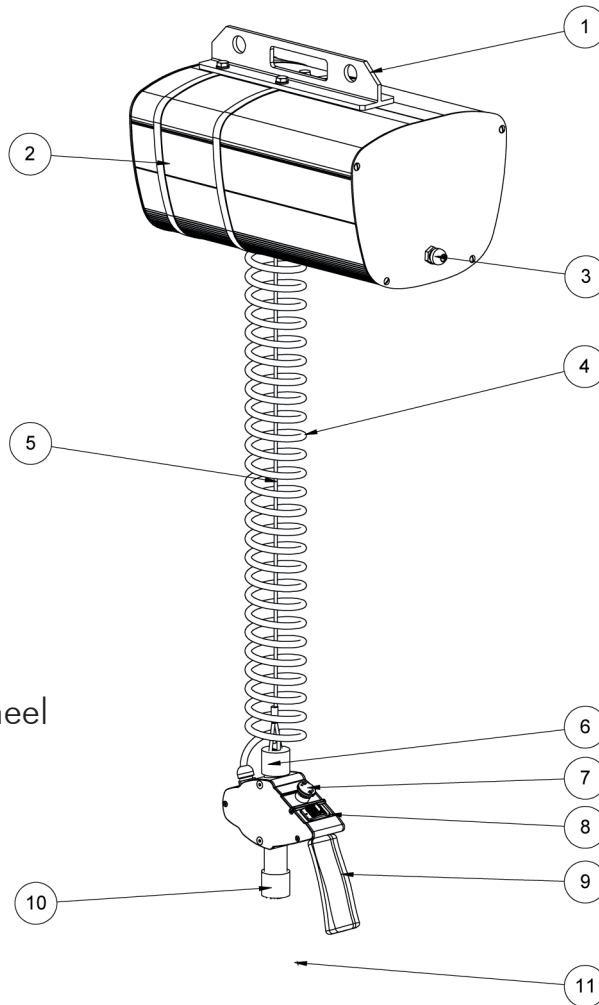

Specification:	VH60	VH120
Lifting capacity	60 kg	120 kg
Power supply	230V +/- 10%	230V +/- 10%
Frequency	47-63 Hz	47-63 Hz
Lifting height	2000 mm	2000 mm
Lifting speed	0.75 m/s	0.35 m/s
Dead weight	22 kg	22 kg
Speed control	Variable	Variable



We are System Integrator of TAWI in Hong Kong

ITL 領捷科技(香港)有限公司
Insights Technology (Hong Kong) Limited

+852 2907 9266 contact@ithkl.com

Contact Us www.ithkl.com [Google Map Us](#)

Mtk0035EN-HOS-03